

## **POOLS — TEMPORARY, INFLATABLE, IN-GROUND, ABOVE GROUND, HOT TUBS & SPAS**

Checklist of what is required to bring pools into compliance and receive a Certificate of Occupancy/ Compliance; ***OR*** to apply for a building permit for new pool installation:

- A copy of the specifications for the pool and pump.
- Plans for the deck, if applicable.
- Copy of survey showing proposed pool (and deck) location.
- Pool alarm that complies with ASTM F2208.
- A minimum 48 inch high permanent barrier with self-closing, self-latching locked gate(s).
- **Temporary / Inflatable pool walls cannot act as its own barrier as it is not rigid (NYS Code Interpretation attached). Other pools, (PVC or metal frame) can act as its own barrier *IF* it maintains 48 inches tall around the entire perimeter; otherwise, it must have its own Code compliant barrier and gate(s).**
- **Electric - Inflatable pools - extension cords cannot be used to power the pump. The pump MUST be plugged directly into a GFCI outlet.**
- Electric - In-Ground pools, above ground pools, and hot tubs/spas: Electrical work MUST be performed by a Putnam County Licensed Electrician and inspected by the Putnam County Electrical Inspector.

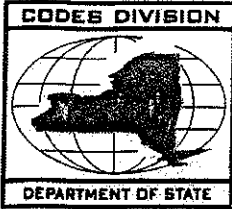

**NEW YORK STATE DEPARTMENT OF STATE**  
Division of Code Enforcement and Administration

Phone : (518) 474-4073  
[www.dos.state.ny.us](http://www.dos.state.ny.us)

Fax : (518) 486-4487  
E-mail: [info@dos.state.ny.us](mailto:info@dos.state.ny.us)

---

**TECHNICAL BULLETIN**

---

**Effective Date:** January 1, 2003

**Source Document:** 19NYCRR 1220 - *Residential Code of New York State (RCNYS)*

**Topic:** Self-set swimming pool with 48 inch wall height

This document is to answer the question whether a self-set or quick-set swimming pool (not rigid metal walls) with 48 inch or more wall height meets the requirements of section AG105.2 of Appendix G of the *Residential Code of New York State (RCNYS)* as a barrier.

NO. Section AG105.2 states in part:

*An outdoor swimming pool, including an in-ground, aboveground or on-ground pool, hot tub or spa shall be provided with a barrier ...*

The term "barrier" is defined as "A fence, wall, building wall or combination thereof which completely surrounds the swimming pool and obstructs access to the swimming pool."

Although the self-set pool has a 48 inch wall, it does not obstruct access because it is not rigid. The wall can easily be deflected by a child who grabs the top inflated ring.

**Ronald E. Piester, R.A., Director**  
**Division of Code Enforcement and Administration**

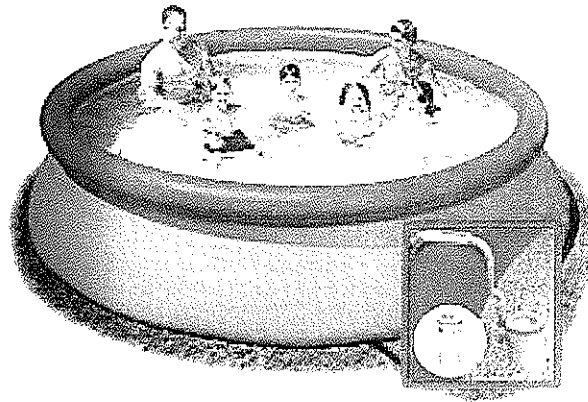

Inflatable or Self-Set Pool (Does not satisfy the 48 inch high barrier requirement regardless of its height)



Metal or PVC Frame pool can act as its own barrier IF it is 48 inches or higher

# POOL FENCE

## AN INVESTMENT WORTH MAKING ...

### AND A REQUIREMENT OF THE CODE!

*Swimming pools, spas, and hot tubs are becoming more frequent in the back yards of homes across the State. While very enjoyable to the users, these places of comfort are very alluring to young children. Protection against unsupervised children is paramount in avoiding a household disaster.*

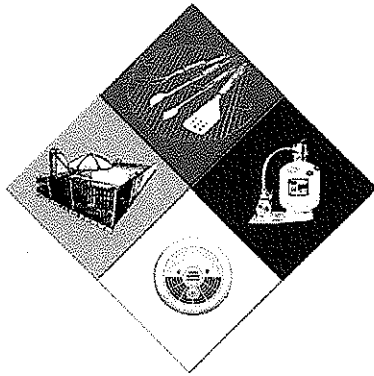

Barriers like pool fences are working! In 1985, New York State started requiring pool fences when the rate of child deaths (newborn to 4 years old) soared to 17 drownings per million. By 1999, that number dropped by 95%.

#### **When do I need a barrier?**

Barriers, such as fences, are required around swimming pools, hot tubs and spas. This includes both fixed and portable units, including pre-formed or inflatable pools. The only exception is when a swimming pool is not able to contain more than 24" of water.

#### **Are existing swimming pools exempt from barrier requirements?**

No. All swimming pools, no matter how old, are required to have a barrier around them. The Property Maintenance Code of New York State requires an approved barrier around all swimming pools, regardless of their age.

#### **What are the requirements for barriers?**

The *Residential Code of New York State* and the *Building Code of New York State* regulate the construction parameters of barriers. Several options are available.

1. A 48" barrier shall surround the pool area. The barrier can be made using various methods including masonry, wood, or metal. Whatever method is used, it must not allow passage of children through the barrier as well as be constructed to prevent climbing.
2. For above ground pools, the side wall can be used as part of the barrier as long as the walls are 48" above the ground and the access ladder is secured. A barrier can be placed on top of the pool if it doesn't quite make the 48" by itself.
3. When the wall of a building serves as the barrier, or a portion thereof, a power operated top can be used or alarms can be placed on the doors leading to the pool area.

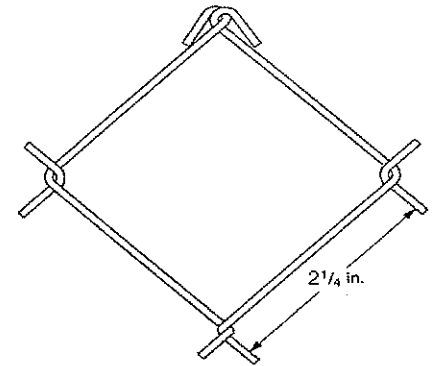

#### **Do I need to put a barrier up to protect my hot tub or spa?**

No. Hot tubs and spas are exempt from the barrier if equipped with a safety cover complying with the ASTM F1346 safety standard.

#### **Do fences, gates and folding ladders need to be locked?**

Yes. Pool gates and folding ladders do need to be locked when unsupervised. This needs to be achieved by a key, combination, or child-proof lock.

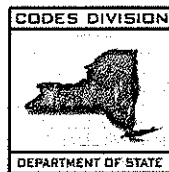
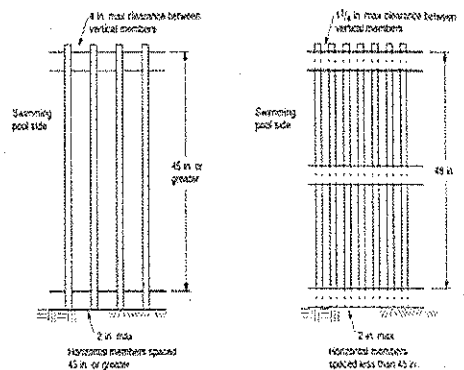

For more information, contact the Department of State Division of Code Enforcement and Administration 41 State St. Albany, NY 12231  
 Phone: (518)-474-4073  
 Fax: (518)-486-4487  
<http://www.dos.state.ny.us>



Specifics on fence construction and permitted gates are found in the Residential Code of New York State and the Building Code of New York State



**RESIDENTIAL CODE OF NEW YORK STATE - APPENDIX G**  
**SWIMMING POOLS, SPAS AND HOT TUBS**

**SECTION AG101**

**GENERAL**

**AG101.1** General. The provisions of this appendix shall control the design and construction of swimming pools, spas and hot tubs installed in or on the lot of a one and two-family dwelling.

**SECTION AG-102**

**DEFINITIONS**

**AG102.1** General. For the purposes of these requirements, the terms used shall be defined as follows as set forth in Chapter 2.

**ABOVE-GROUND/ON-GROUND POOL.** See "Swimming pool"

**BARRIER.** A fence, wall, building wall or combination there of which completely surrounds the swimming pool and obstructs access to the swimming pool.

**HOT TUB.** See "Swimming Pool."

**In-GROUND POOL.** See "Swimming Pool."

**RESIDENTIAL.** That which is situated on the premises of a detached one or two-family dwelling or a one family townhouse not more than three stories in height.

**SPA. NONPORTABLE.** See "Swimming pool."

**SPA. PORTABLE.** A nonpermanent structure intended for recreational bathing, in which all controls, water heating and water circulating equipment are an integral part of the product.

**SWIMMING POOL.** Any structure intended for swimming or recreational bathing that contains water over 24 inches (610 mm) deep. This includes in-ground, aboveground and on-ground swimming pools, hot tubs and spas.

**SWIMMING POOL, INDOOR.** A swimming pool that is totally contained within a structure and surrounded on all four sides by walls of said structure.

**SECTION AG103**

**SWIMMING POOLS**

**AG103.** In ground pools. In ground pools shall be designed and constructed in conformance with ANSI/NSPI-4 as listed in Section AG107.

**SECTION AG-104**

**SPAS AND HOT TUBS**

**AG104.1** Permanently installed spas and hot tubs. Permanently installed spas and hot tubs shall be designed and constructed in conformance with ANSI/NSPI-3 as listed in Section AG107.

**AG104.2** Portable spas and hot tubs. Portable spas and hot tubs shall be designed and constructed in conformance with ANSI/NSPI-6 as listed in Section AG107.

**SECTION AG105 -**

**BARRIER REQUIREMENTS**

**AG105.1** Application. The provisions of this chapter shall control the design of barriers for residential swimming pools, spas and hot tubs. These design controls are intended to provide protection against potential drowning and near drowning by restricting access to swimming pools, spas and hot tubs.

**AG105.2** Outdoor swimming pool. An outdoor swimming pool, including an in ground, aboveground or on ground pool, hot tub or spa shall be provided with a barrier which shall comply with the following:

1. The top of the barrier shall be at least 48 inches (1219mm) above the grade, measured on the side of the barrier, which faces away from the swimming pool. The maximum vertical clearance between grade and the bottom of the barrier shall be 2 inches (51mm) measured on the side barrier, which faces away from the swimming pool. Where the top of the pool structure is above grade, such as an above ground pool, the barrier may be at ground level, such as the structure, or mounted on top of the pool structure. Where the barrier is mounted on top of the pool structure, the maximum vertical clearance

between the top of the pool structure and the bottom of the barrier shall be 4 inches. (102mm).

2. Openings in the barrier shall not allow passage of a 4-inch diameter (102mm) sphere.

3. Solid barriers, which do not have openings, such as masonry or stonewall, shall not contain indentations or protrusions except for normal construction tolerances and tooled masonry joints.

4. Where the barrier is composed of horizontal and vertical members and the distance between the tops of the horizontal members is less than 45 inches (1143mm), the horizontal members shall be located on the swimming pool side of the fence. Spacing between vertical members shall not exceed 1.75 inches (44mm) in width. Where there are decorative cutouts within vertical members, spacing within the cutouts shall not exceed 1.75 (44mm) inches in width.

5. Where the barrier is composed of horizontal and vertical members and the distance between the tops of the horizontal members is 45 inches (1145mm) or more, spacing between vertical members shall not exceed 4 inches (102mm). Where there are decorative cutouts within vertical members, spacing within the cutouts shall not exceed 1.75 inches (44mm) in width.

6. Maximum mesh size for chain link fences shall be a 1.25 inch (32mm) square unless the fence is provided with slats fastened at the top or the bottom which reduce the openings to not more than 1.75 inches (44mm).

7. Where the barrier is composed of diagonal members, such as a lattice fence, the maximum openings formed by the diagonal members shall not be more than 1.75 inches (44mm).

8. Access gates shall comply with the requirements of Section AG105.2. Items 1 through 7, and shall be securely locked with a key, combination or other child proof lock sufficient to prevent access to the swimming pool through such gate when the swimming pool is not in use or supervised. Pedestrian access gates shall open outward away from the pool and shall be self-closing and have a self-latching device. Gates other than pedestrian gates shall have a self-latching device. Where the release mechanism of the self-latching device is located less than 54 inches (1372mm) from the bottom of the gate, the release mechanism and openings shall comply with the following.

8.1 The release mechanism shall be located on the pool side of the

gate at least 3 inches (76mm) below the top of the gate, and

8.2 The gate and barrier shall have no openings greater than 0.5 inch

(12.7mm) within 18 inches (457mm) of the release mechanism.

9. Where a wall of a dwelling serves as part of the barrier one following

conditions must be met:

9.1 The pool shall be equipped with a powered safety cover in compliance with ASTM F1346 or

9.2 All doors with direct access to the pool through that wall shall be

equipped with an alarm which produces an audible warning

when the door and its screen, if present are opened. The alarm

shall sound continuously for a minimum of 30 seconds

immediately after the door is opened and be capable of being

heard throughout the house during normal household activities.

The alarm shall automatically reset under all conditions. The alarm

system shall be equipped with a manual means, such as a touchpad

or switch to temporarily deactivate the alarm for a single opening.

Such deactivation shall last for not more than 15 seconds. The

deactivation switch (es) shall be located at least 54 inches

(1372mm) above the threshold of the door; or

9.3 Other means of protection, such as self-closing doors with self-

latching devices which are approved by the governing body, shall

be acceptable so long as the degree of protection afforded is no

less than the protection afforded by Item 9.1 or 9.2 described

above.

10. Where an above ground pool structure is used as a barrier or where the barrier is mounted on top of the pool structure, and the means of access is a ladder or steps, then:

10.1 The ladder or steps shall be capable of being secured, locked or removed to prevent access, or

10.2 The ladder or steps shall be surrounded by a barrier, which meets the requirements of section AG105.2, items 1 through 9. When the ladder or steps are secured, locked or removed, any opening created shall not allow the passage of a 4-inch diameter (102mm) sphere.

**AG105.3 INDOOR SWIMMING POOL.** All walls surrounding an indoor swimming pool shall comply with Section AG105.2 item 9.

**AG105.4 PROHIBITED LOCATIONS.** Barriers shall be located so as to prohibit permanent structures, equipment or similar objects from being used to climb the barriers.

**AG105.5 BARRIER EXCEPTIONS.** Spas or hot tubs with a safety cover, which complies with **ASTM F1346**, as listed in Section AG107, shall be exempt from the provisions of this appendix.

## SECTION AG106

### ABBREVIATIONS

#### AG106.1 General.

ANSI--- AMERICAN NATIONAL STANDARDS INSTITUTE

WEST 42<sup>ND</sup> STREET, NEW YORK, NY 10036

ASTM---AMERICAN SOCIETY FOR TESTING AND MATERIALS

1916 RACE STREET, PHILADELPHIA, PA 19103

NSPI---NATIONAL SPA AND POOL INSTITUTE

11 EISENHOWER AVE., ALEXANDRIA, VA 22314

## SECTION AG107

### STANDARDS

#### AG107.1 GENERAL.

#### ANSI/NSPI

ANSI/NSPI-3 Standard for permanently installed Residential spas. ----- AG104.1

ANSI/NSPI-4 Standard for above-ground/on ground Residential swimming pools-----AG103.2

ANSI/NSPI-5 Standard for residential in-ground Swimming pools-----AG103.1

ANSI/NSPI-6 Standard for residential Portable spas-----AG104.2

#### ASTM

ASTM F 1346-91 Standard performance specifications for safety covers and labeling requirements for all covers for swimming pools, spas and hot tubs-----AG105.2, AG105.5